

# MBR30200CT

30.0 AMP SCHOTTKY BARRIER RECTIFIERS



## FEATURES

- \* Low forward voltage drop
- \* High current capability
- \* High reliability
- \* High surge current capability
- \* Epitaxial construction

## MECHANICAL DATA

- \* Case: Molded plastic
- \* Epoxy: UL 94V-0 rate flame retardant
- \* Lead: Lead solderable per MIL-STD-202, method 208 guaranteed
- \* Polarity: As Marked
- \* Mounting position: Any
- \* Weight: 1.81 grams
- \* Lead Free Finish/RoHS Compliant

## VOLTAGE RANGE

200 Volts

## CURRENT

30.0 Ampere

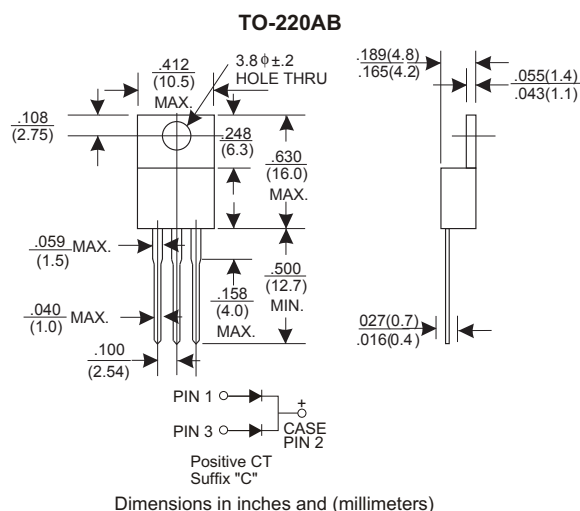

## MAXIMUM RATINGS AND ELECTRICAL CHARACTERISTICS

Rating 25°C ambient temperature unless otherwise specified.  
Single phase half wave, 60Hz, resistive or inductive load.  
For capacitive load, derate current by 20%.

TYPE NUMBER	MBR30200CT	UNITS
Maximum Recurrent Peak Reverse Voltage	200	V
Maximum RMS Voltage	140	V
Maximum DC Blocking Voltage	200	V
Maximum Average Forward Rectified Current See Fig. 1	30	A
Peak Forward Surge Current, 8.3 ms single half sine-wave superimposed on rated load (JEDEC method)	250	A
Maximum Instantaneous Forward Voltage per Leg at 15.0A	0.95	V
Maximum DC Reverse Current Ta=25°C	500	uA
at Rated DC Blocking Voltage Ta=100°C	30	mA
Typical Thermal Resistance RθJC (Note 1)	1.4	°C/W
Operating Temperature Range Tj	-65 — +150	°C
Storage Temperature Range TSTG	-65 — +150	°C

### NOTES:

1. Thermal Resistance Junction to Case.

RATING AND CHARACTERISTIC CURVES MBR30200CT

FIG.1-TYPICAL FORWARD CURRENT DERATING CURVE

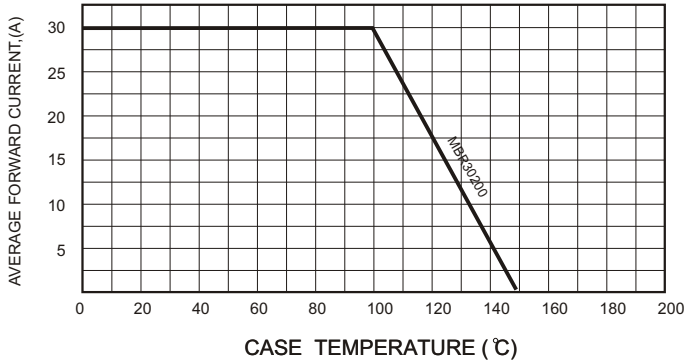

FIG.2-TYPICAL FORWARD CHARACTERISTICS

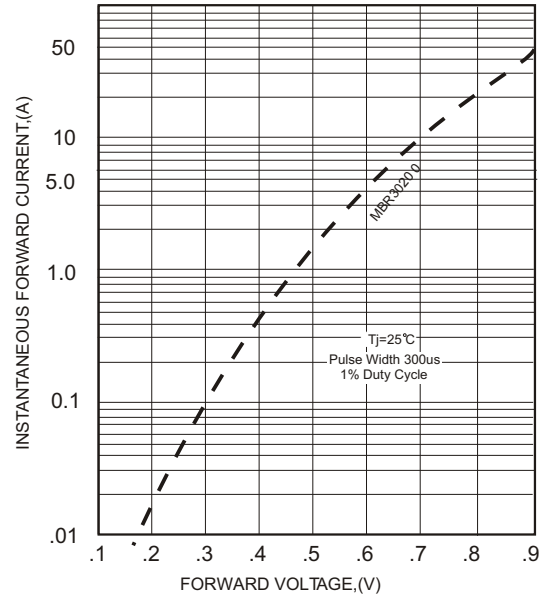

FIG.3 - TYPICAL REVERSE CHARACTERISTICS

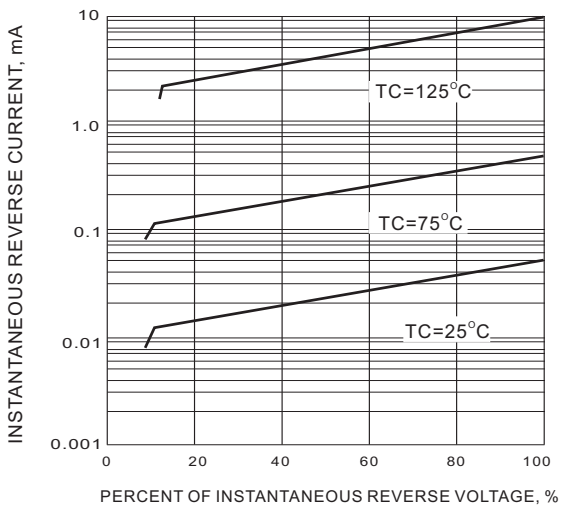

FIG.4-MAXIMUM NON-REPETITIVE FORWARD SURGE CURRENT

