

ES2AF THRU ES2JF

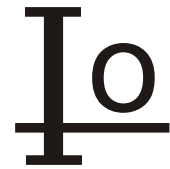

2.0 AMP SUPER FAST RECTIFIERS

FEATURES

- * Ideal for surface mount applications
- * Easy pick and place
- * Built-in strain relief
- * High surge current capability
- * Lead Free Finish/RoHS Compliant

MECHANICAL DATA

- * Case: Molded plastic
- * Epoxy: UL 94V-0 rate flame retardant
- * Metallurgically bonded construction
- * Polarity: Color band denotes cathode end
- * Mounting position: Any
- * Weight: 0.064 grams

VOLTAGE RANGE

50 to 600 Volts

CURRENT

2.0 Ampere

SMAFL

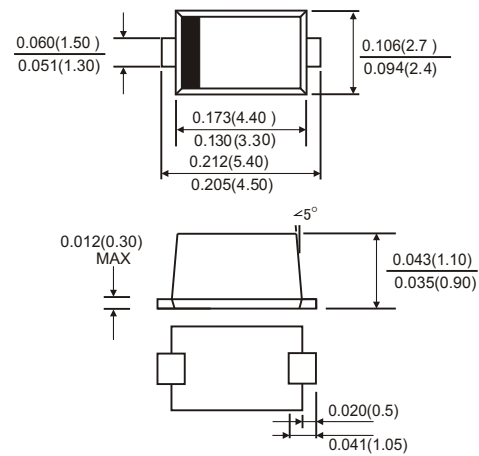

Dimensions in inches and (millimeters)

MAXIMUM RATINGS AND ELECTRICAL CHARACTERISTICS

Rating 25°C ambient temperature unless otherwise specified.
Single phase half wave, 60Hz, resistive or inductive load.
For capacitive load, derate current by 20%.

TYPE NUMBER	ES2AF	ES2BF	ES2CF	ES2DF	ES2EF	ES2GF	ES2JF	UNITS	
Maximum Recurrent Peak Reverse Voltage	50	100	150	200	300	400	600	V	
Maximum RMS Voltage	35	70	105	140	210	280	420	V	
Maximum DC Blocking Voltage	50	100	150	200	300	400	600	V	
Maximum Average Forward Rectified Current									
.375"(9.5mm) Lead Length at Ta=55°C								2.0	A
Peak Forward Surge Current, 8.3 ms single half sine-wave superimposed on rated load (JEDEC method)								50	A
Maximum Instantaneous Forward Voltage at 2.0A			0.95			1.25	1.70	V	
Maximum DC Reverse Current Ta=25°C								5.0	uA
at Rated DC Blocking Voltage Ta=100°C								150	uA
Maximum Reverse Recovery Time (Note 1)								35	nS
Typical Junction Capacitance (Note 2)								25	pF
Operating and Storage Temperature Range Tj, TSTG								-65 — +150	°C

NOTES:

1. Reverse Recovery Time test condition: IF=0.5A, IR=1.0A, IRR=0.25A
2. Measured at 1MHz and applied reverse voltage of 4.0V D.C.

RATING AND CHARACTERISTIC CURVES (ES2AF THRU ES2JF)

FIG.1- TEST CIRCUIT DIAGRAM AND REVERSE RECOVERY TIME CHARACTERISTIC

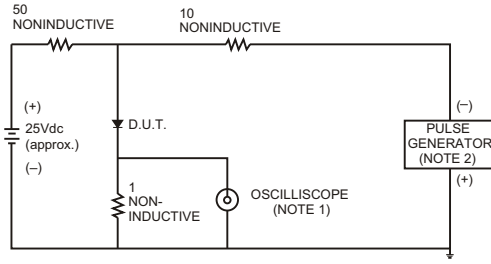

NOTES: 1. Rise Time= 7ns max., Input Impedance= 1 megohm.22pF.
2. Rise Time= 10ns max., Source Impedance= 50 ohms.

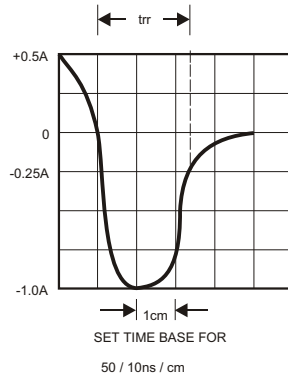

FIG.2-TYPICAL FORWARD CURRENT DERATING CURVE

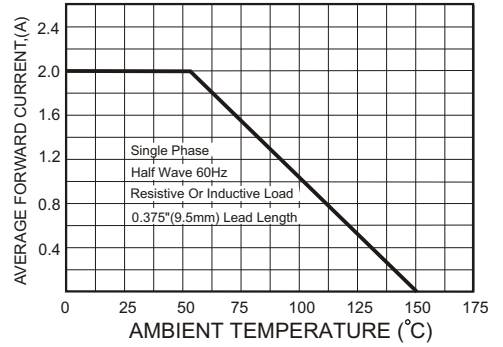

FIG.3-TYPICAL FORWARD CHARACTERISTICS

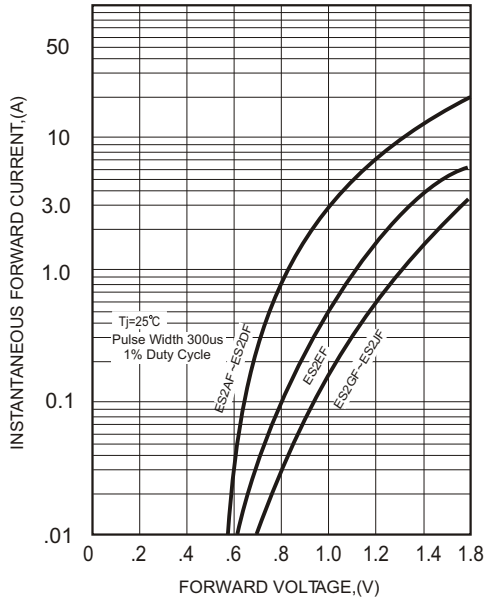

FIG.4-TYPICAL REVERSE CHARACTERISTICS

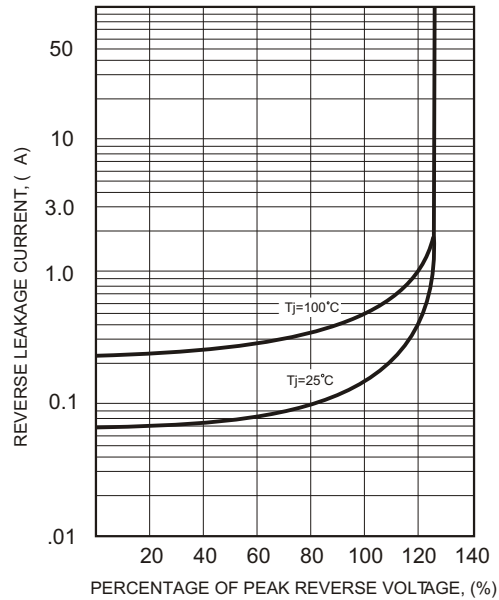

FIG.5-MAXIMUM NON-REPETITIVE FORWARD SURGE CURRENT

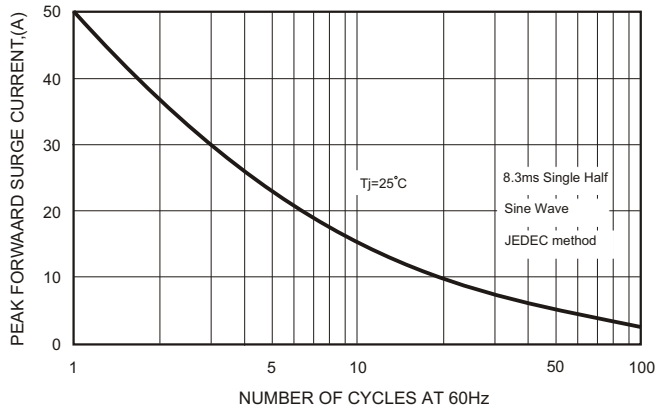

FIG.6-TYPICAL JUNCTION CAPACITANCE

