

KBJ6A THRU KBJ6M

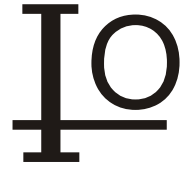

SINGLE PHASE 6.0 AMPS GLASS PASSIVATED BRIDGE RECTIFIERS

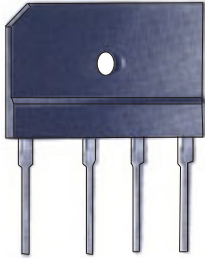

FEATURES

- * Ideal for printed circuit board
- * Low forward voltage
- * Low leakage current
- * Polarity: marked on body
- * Mounting position: Any
- * Lead Free Finish/RoHS Compliant

VOLTAGE RANGE

50 to 1000 Volts

CURRENT

6.0 Ampere

KBJ

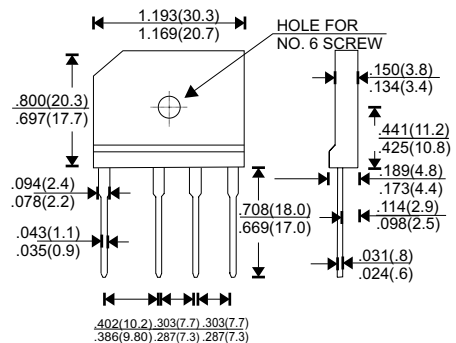

MAXIMUM RATINGS AND ELECTRICAL CHARACTERISTICS

Rating 25°C ambient temperature unless otherwise specified.
Single phase half wave, 60Hz, resistive or inductive load.
For capacitive load, derate current by 20%.

TYPE NUMBER	KBJ6A	KBJ6B	KBJ6D	KBJ6G	KBJ6J	KBJ6K	KBJ6M	UNITS	
Maximum Recurrent Peak Reverse Voltage	50	100	200	400	600	800	1000	V	
Maximum RMS Voltage	35	70	140	280	420	560	700	V	
Maximum DC Blocking Voltage	50	100	200	400	600	800	1000	V	
Maximum Average Forward Rectified Current									
.375"(9.5mm) Lead Length at Tc=50°C								6.0	A
Peak Forward Surge Current, 8.3 ms single half sine-wave superimposed on rated load (JEDEC method)								135	A
Maximum Forward Voltage Drop per Bridge Element at 3.0A D.C.								1.1	V
Maximum DC Reverse Current Ta=25°C								10	uA
at Rated DC Blocking Voltage Ta=100°C								200	uA
Storage Temperature Range, TSTG								-55 — +150	°C

RATING AND CHARACTERISTIC CURVES (KBJ6A THRU KBJ6M)

FIG.1-TYPICAL FORWARD CURRENT DERATING CURVE

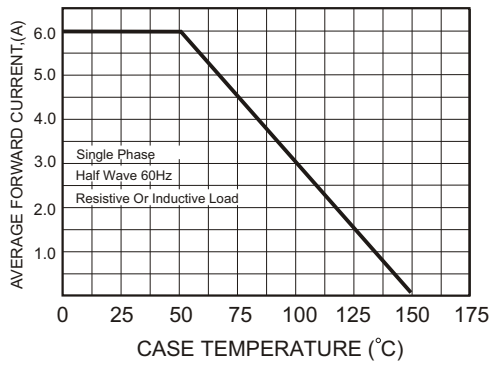

FIG.2-MAXIMUM NON-REPETITIVE FORWARD SURGE CURRENT

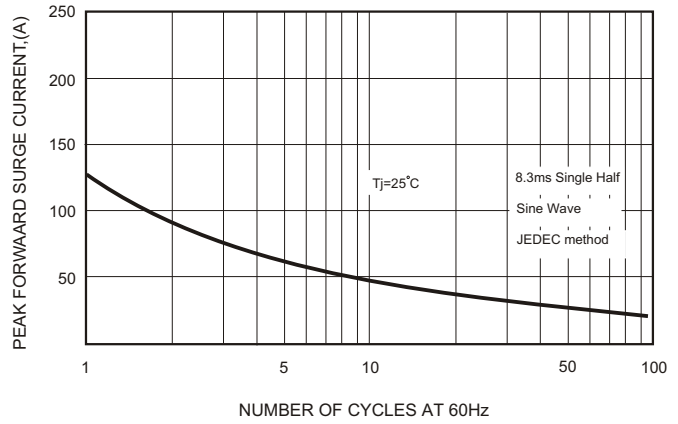

FIG.3-TYPICAL FORWARD CHARACTERISTICS

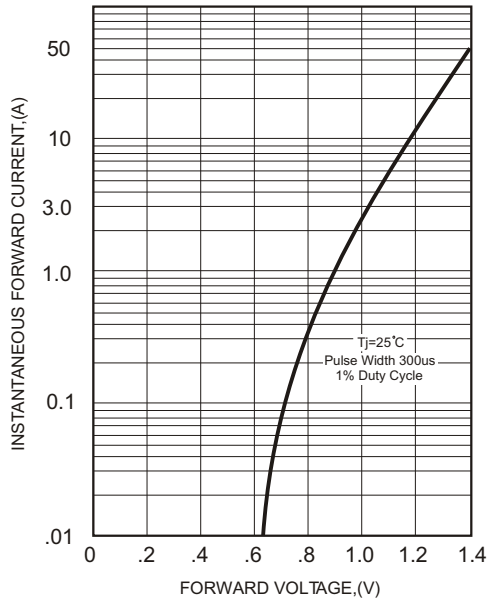

FIG.4-TYPICAL REVERSE CHARACTERISTICS

