

# MUR1020 THRU MUR1060

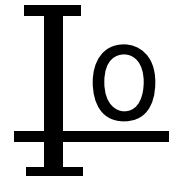

GLASS PASSIVATED SUPER FAST RECTIFIER

Forward Current - 10.0Amperes



## FEATURES

- Plastic package has Underwriters Laboratory Flammability Classification 94V-0
- Fast switching for high efficiency
- Low forward voltage drop
- Single rectifier construction
- High surge capability
- For use in low voltage ,high frequency inverters, free wheeling ,and polarity protection applications
- High temperature soldering guaranteed:260 C/10 seconds, 0.25"(6.35mm)from case
- Component in accordance to RoHS 2002/95/EC and WEEE 2002/96/EC
- \* Lead Free Finish/RoHS Compliant

## MECHANICAL DATA

- Case: JEDEC TO-220AB molded plastic body
- Terminals: Lead solderable per MIL-STD-750,method 2026
- Polarity: As marked
- Mounting Position: Any
- Weight: 1.81 gram

## VOLTAGE RANGE

200 to 600 Volts

## CURRENT

10.0Ampere

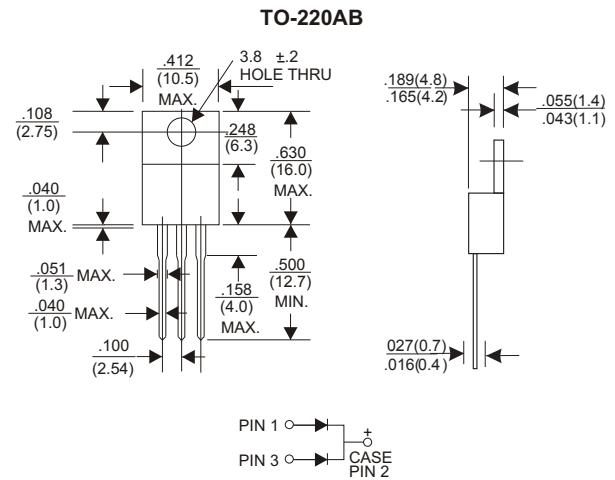

Dimensions in inches and (millimeters)

## MAXIMUM RATINGS AND ELECTRICAL CHARACTERISTICS

(Ratings at 25°C ambient temperature unless otherwise specified ,Single phase ,half wave ,resistive or inductive load. For capacitive load,derate by 20%.)

	Symbols	MUR 1020	MUR 1040	MUR 1060	Units
Maximum repetitive peak reverse voltage	V <sub>RRM</sub>	200	400	600	Volts
Maximum RMS voltage	V <sub>RMS</sub>	140	280	420	Volts
Maximum DC blocking voltage	V <sub>DC</sub>	200	400	600	Volts
Maximum average forward rectified current(see Fig.1)	Per leg	5.0			Amps
	Total device	10.0			
Peak forward surge current 8.3ms single half sine-wave superimposed on rated load (JEDEC method)	I <sub>FSM</sub>	150.0			Amps
Maximum instantaneous forward voltage at 5.0A(Note 1 )	V <sub>F</sub>	0.95	1.3	1.7	Volts
Maximum instantaneous reverse current at rated DC blocking voltage(Note 1)	I <sub>R</sub>	T <sub>A</sub> = 25°C	5		uA
		T <sub>A</sub> = 125°C	500		
Maximum Reverse Recovery Time (Note 2)	T <sub>rr</sub>	35			ns
Typical thermal resistance (Note 3)	R <sub>θJC</sub>	2.5			°C/W
Operating junction temperature range	T <sub>J</sub>	-40 to +150			°C
Storage temperature range	T <sub>STG</sub>	-40 to +150			°C

Notes: 1. Pulse test: 300μs pulse width, 1% duty cycle

2. Reverse recovery test conditions I<sub>F</sub>=0.5A,I<sub>R</sub>=1.0A, I<sub>rr</sub>=0.5A

3. Thermal resistance from junction to case

# RATINGS AND CHARACTERISTIC CURVES MUR1020 THRU MUR1060

FIG.1-FORWARD CURRENT DERATING CURVE

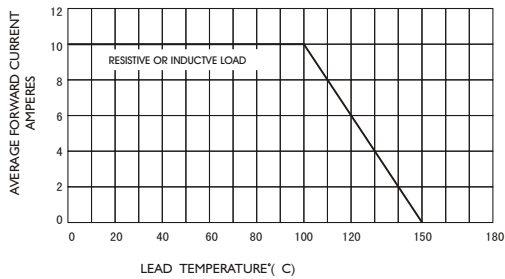

FIG.2-MAXIMUM NON-REPETITIVE PEAK FORWARD SURGE CURRENT

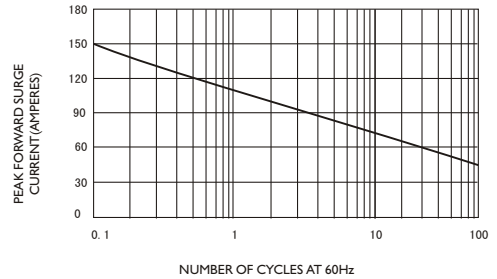

FIG.3-TYPICAL INSTANTANEOUS FORWARD CHARACTERISTICS

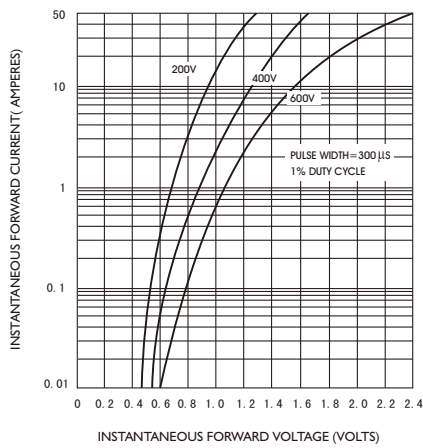

FIG.4-TYPICAL REVERSE CHARACTERISTICS

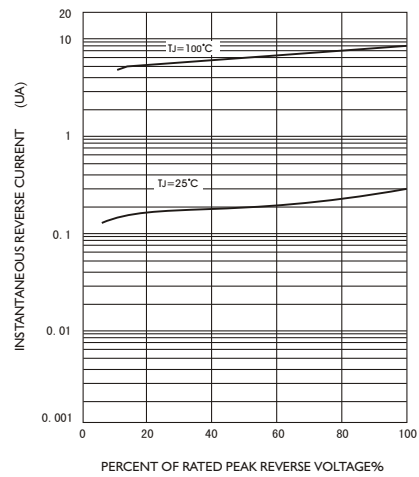

FIG.5-TYPICAL JUNCTION CAPACITANCE

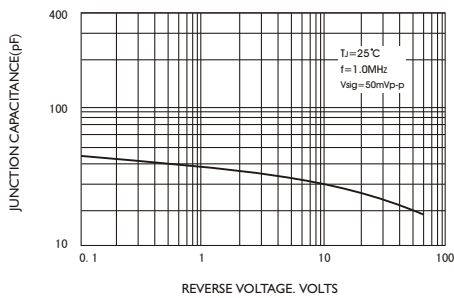

FIG.6-TYPICAL TRANSIENT THERMAL IMPEDANCE

